

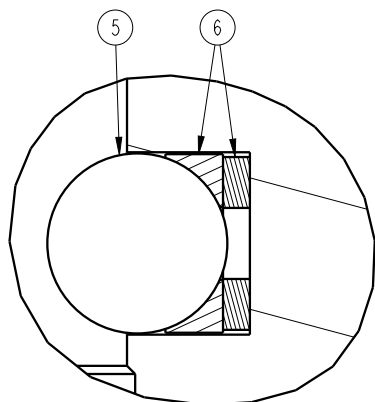

NO.	QTY.	DESCRIPTION			STANDARD SEAL KIT	FLUOROCARBON SEAL KIT
			14-0209-01-X-PR	14-0213-01-X-PR		
1	1	BUTTON HEAD CAP SCREW	21-4100-09	21-4100-39	NO	NO
2	1	WIPER, ROD (FLUOROCARBON)	39-0530-01	39-0530-00	YES	YES
3	1	BACK-UP RING, ROD	39-F540-01	39-F540-02	YES	YES
4	1	SEAL, ROD (STANDARD)	39-0100-20	39-0110-46	YES	NO
	1	SEAL, ROD (FLUOROCARBON)	39-V100-20	39-V110-46	NO	YES
5	3	BALL, STEEL ALLOY	23-6000-11	23-6000-02	YES	YES
6	3	BALL SEAT ASSEMBLY	90-1999-57	90-1999-58	YES	YES
7	1	PLUNGER, LEFT HAND (SHOWN)	81-4000-51	81-4000-52	NO	NO
	1	PLUNGER, RIGHT HAND	81-4000-48	81-4000-49	NO	NO
8	1	SEAL, PLUNGER (STANDARD)	39-H100-18	39-H110-30	YES	NO
	1	SEAL, PLUNGER (FLUOROCARBON)	39-V100-18	39-V110-30	NO	YES
9	1	SOCKET HEAD CAP SCREW	21-4100-73	21-4100-73	NO	NO
10	1	WASHER	23-0500-11	23-0500-11	NO	NO
11	1	PLUNGER BUSHING	81-5000-13	81-5000-14	NO	NO
12	1	ACTUATOR ROD	81-5005-08	81-5005-09	NO	NO
13	1	O-RING, RETAINER (FLUOROCARBON)	39-0510-31	39-V510-43	YES	YES
14	1	SEAL, LOADED LIP	39-0520-31	39-0520-31	YES	NO
	1	SEAL, LOADED LIP (FLUOROCARBON)	39-V520-36	39-V520-36	NO	YES
15	1	RETAINER	81-4000-53	81-4000-54	NO	NO
16	1	WIPER (FLUOROCARBON)	39-0530-23	39-0530-23	YES	YES
N/A	N/A	SEAL KIT (STANDARD)	60-1400-33	60-1400-34	INCLUDED IN KIT	
N/A	N/A	SEAL KIT (FLUOROCARBON)	6V-1400-33	6V-1400-34		

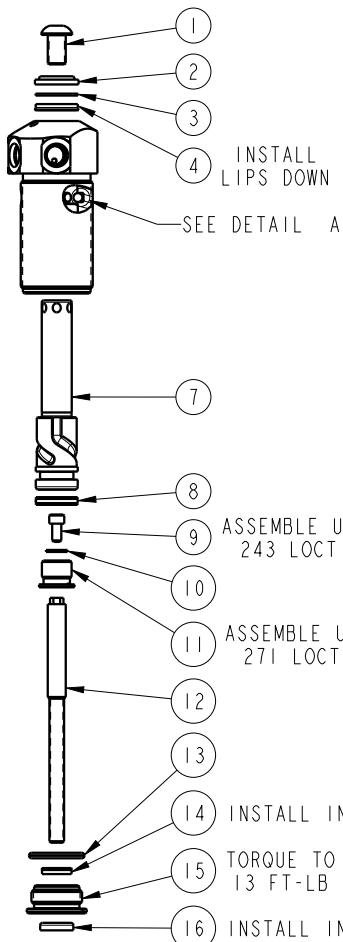

Lubricate all seals with clean hydraulic fluid prior to assembly.

PARTS LIST	 VEKTEK, INC. 1334 E. SIXTH AVE. P.O. BOX 625 EMPORIA, KS. 66801 U.S.A.
ASSEMBLIES AFFECTED 14-0209-01-L-PR, 14-0209-01-L-F-PR 14-0209-01-R-PR, 14-0209-01-R-F-PR 14-0213-01-L-PR, 14-0213-01-L-F-PR 14-0213-01-R-PR, 14-0213-01-R-F-PR	SIZE A
DATE: 03/10/05	REV E

E	5279	RELEASE	ALS	5/6/24
REV	IN ACCORDANCE WITH ECN	EFFECTIVE DATE	REVISED BY	DATE
DRW BY:	JAW	DRAWING STATUS: Released		
PRODUCTION APPROVED FOR RELEASED STATUS ONLY				